

GENUINE
blue

URO®

**Shackle & Suspension
Systems**

**FREIGHTLINER
FAMILY**
INCLUDING
STERLING & WESTERN STAR



INFO FACTS

The **URO**® Shackle System has a freely rotating spring pin design and a specially formulated urethane that is self-lubricating and abrasion resistant. The **URO**® Shackle provides superior dampening and suspension control over the original equipment bushings. It extends component life and improves overall vehicle handling as well as greatly reduces wear on the leaf springs and hangers.

The **URO**® Shackle System design is backed by:

3 YEAR PARTS & LABOR WARRANTY

MAINTENANCE FREE

LOWER MAINTENANCE COSTS

INCREASED SERVICE LIFE 3 TO 5 TIMES

EASY INSTALLATION

IMPROVES RIDE QUALITY

QUIETER RIDE

**INCREASED CONTROL OVER
SUSPENSION MOVEMENT TO MAINTAIN ALIGNMENT;
IMPROVES HANDLING, &
EXTENDS TIRE LIFE.**

www.urobushings.com

FREIGHTLINER FAMILY APPLICATIONS

INCLUDING STERLING & WESTERN STAR

MODELS / CHASSIS	Location	URO® Kit No.	Front of Front Spring Pin	Bushing Dimension	Special Comments
FREIGHTLINER					
I20 Series Conventional COE, FLD 112 Conventional	Front	TD4600	TD461408	1-1/2" O.D.	
Air Liner II	Rear	TD234	----	2-1/2" O.D.	Air Suspension
FH36-40 Suspension	Torque Rod	TD5047691	----	2" O.D.	Torque Rod Bushing
FLC12 CONVENTIONAL	Front	TD4610	TD461409	1-1/2" O.D.	
	Front	TD4620	TD461430	1-3/8" O.D.	
	Front	TD4630	TD461430	1-1/2" O.D.	
AIRTEK	Front	TBA	TBA	---	
SOFTEK/COMTEK	Front	TBA	TBA	---	
Air Liner II	Rear	TD234	----	----	Air Suspension
	Torque Rod	TD5044695	---	2-3/4" OD.	Torque Rod Bushing
	Torque Rod	TD5047691	---	2" OD.	Torque Rod Bushing
	Torque Rod	TD5044697	---	2-3/4" OD.	Torque Rod Stud
Business Class MB/FL 50, 60, 70, 80 & FL106	Front	TD4640	TD211	57MM x 100MM	4" Wide Leaf Spring
	Front	TD4650	TD212	57MM x 75MM	3" Wide Leaf Spring
	Rear	TBA	----	---	
FS65 CHASSIS	Front	TD4640	TD211	57MM x 100MM	4" Wide Leaf Spring
Air Liner II	Rear	TD234	----	2-1/2" O.D.	Air Suspension
STERLING					
A-AT 9513, AT9522 L-LT8513, LT9513, LT9522 Aceterra & Conventional	Front	TD4300	----	1-1/2" O.D.	4" Leaf Spring
Air Suspension	Rear	TD234	----	2-1/2" O.D.	FAS II Model
	Torque Rod	TD5044695	----	2-3/4" O.D.	Torque Rod Bushing
	Torque Rod	TD5047691	----	2" O.D.	Torque Rod Bushing
	Torque Rod	TD5044697	----	2-3/4" O.D.	Torque Rod Stud
WESTERN STAR					
CONVENTIONAL	Front	TD9400	----	1-3/8" O.D.	1-1/8" Spring Pin
	Front	TD9410	---	1-1/4 O.D.	1" Spring Pin
Air Suspension	Rear	TD234	----	2-1/2" O.D.	FAS II Model

Upgrade your suspension for a
Quieter, Softer Ride
and completely *Maintenance Free*
Specify

URO®

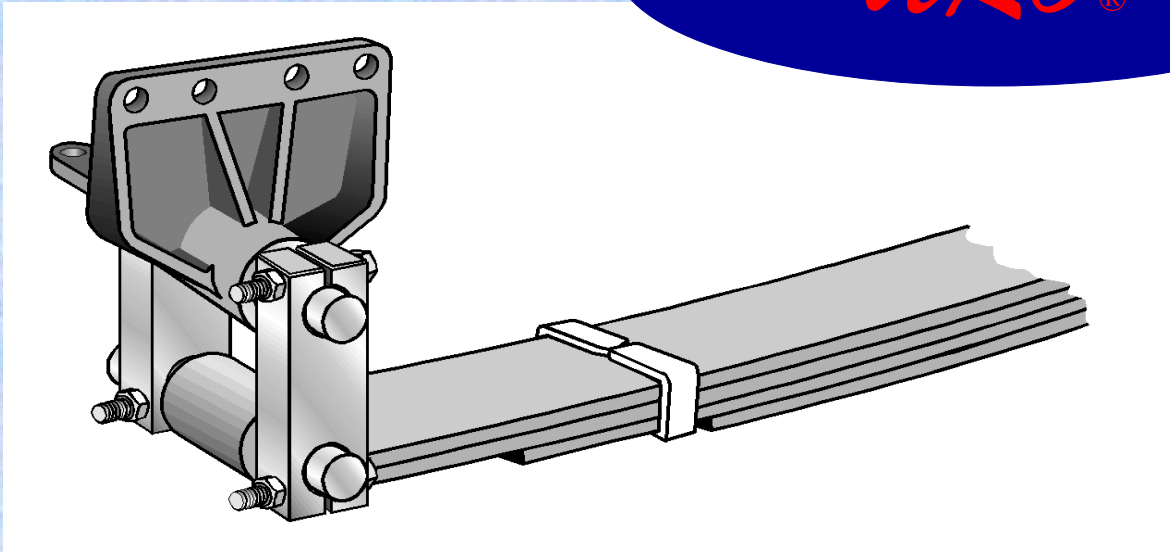

DISTRIBUTED BY:

URO Systems, LLC

15678 King Drive
Meadville, PA 16335
800-541-3229
814-333-2985

sales@urobushings.com

www.urobushings.com

Copyright 2007

URO® Systems, LLC

All rights Reserved

Form 2007-6FF