

GENUINE
blue

URO®

**Shackle & Suspension
Systems**

**VOLVO & MACK
MODELS**



INFO FACTS

The **URO**® Shackle System has a freely rotating spring pin design and a specially formulated urethane that is self-lubricating and abrasion resistant. The **URO**® Shackle provides superior dampening and suspension control over the original equipment bushings. It extends component life and improves overall vehicle handling as well as greatly reduces wear on the leaf springs and hangers.

The **URO**® Shackle System design is backed by:

3 YEAR PARTS & LABOR WARRANTY

MAINTENANCE FREE

LOWER MAINTENANCE COSTS

INCREASED SERVICE LIFE 3 TO 5 TIMES

EASY INSTALLATION

IMPROVES RIDE QUALITY

QUIETER RIDE

**INCREASED CONTROL OVER
SUSPENSION MOVEMENT TO MAINTAIN ALIGNMENT;
IMPROVES HANDLING, &
EXTENDS TIRE LIFE.**

www.urobushings.com

VOLVO & MACK APPLICATIONS

MODELS / CHASSIS	Location	<i>URO</i> [®] Kit No.	Front of Front Spring Pin	Bushing Dimension	Special Comments
MACK					
CH,CL,RW,MH SERIES	Front	TD6200	TD165	48MM O.D.	4" Spring
	Front	TD6210	TD188	48MM O.D.	3-1/2" Spring
	Front	TD6220	—	1-7.8" O.D.	4" Spring
	Front	TD6230	—	1-49/64" O.D.	3-1/2" Spring
Hendrickson Air Suspension	Rear	TD5047691	----	2" O.D.	Torque Rod Bushing
	Torque Rod	TD5044695	----	2-3/4" O.D.	Torque Rod Bushing
	Torque Rod	TD5044697	----	2-3/4" O.D.	Torque Rod Stud
SS 34, 38, 44 Series Camelback	Rear	TD6240000	—	4" Leaf Spring	Complete Upper & Lower Pad OH Kit
SS 34, 38, 44 Series Camelback	Trunion	TD62130PI	—	4" Leaf Spring	Complete Trunion Kit
SS 55, 65 Series	Rear	TD6250000	—	5" Leaf Spring	Complete Upper & Lower Pad OH Kit
VOLVO					
Expeditor, Road Comander {1976 thru 1982}	Front	TD9600	TD961354	1-3/8" O.D.	
WI, WC {1983 thru 1997}	Front	TD9600	TD961354	1-3/8" O.D.	
	Rear	----	----	----	
VHD,VL,VM,VN,VT880	Front	TD9610		45MM O.D.	105 MM Leaf Spring Hanger Modification Required
Single Axle Variable Rate	Rear	TD5044694		2-17/32" O.D.	
Volvo Corporate Ride	Rear	TD5044694		2-17/32" O.D.	
	Torque Rod	TD5047691	----	2" O.D.	Torque Rod Bushing
	Torque Rod	TD5044695	----	2-3/4" O.D.	Torque Rod Bushing
	Torque Rod	TD5044697	----	2-3/4" O.D.	Torque Rod Stud
AIRTEK	Front	TBA	TBA	—	
SOFTEK	Front	TBA	TBA	—	

Upgrade your suspension for a
Quieter, Softer Ride
and completely Maintenance Free
Specify

URO®

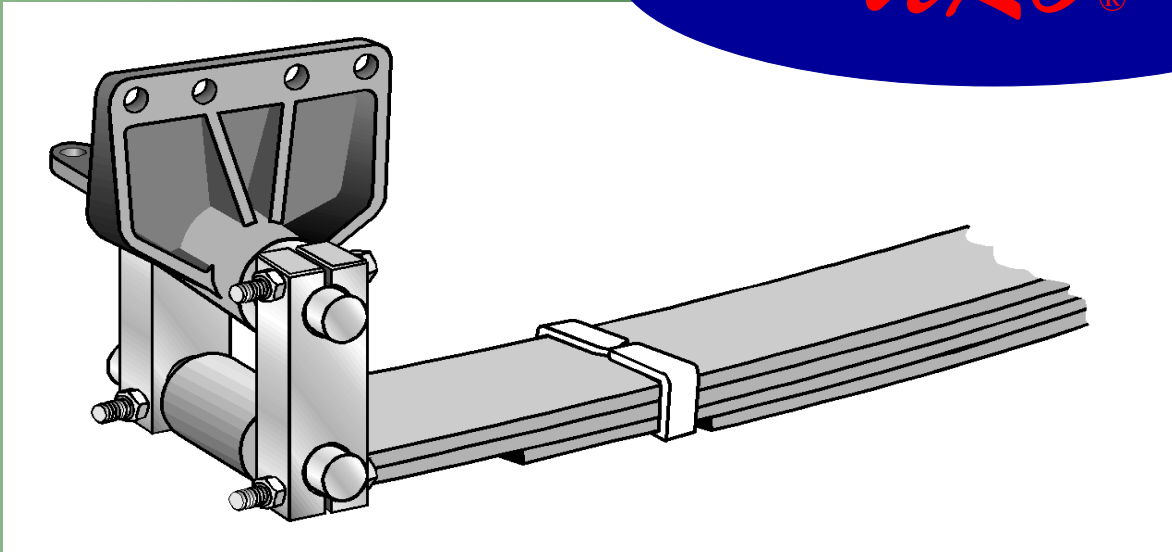

DISTRIBUTED BY:

URO Systems, LLC

15678 King Drive
Meadville, PA 16335
800-541-3229
814-333-2985

sales@urobushings.com

www.urobushings.com