

A WORLD OF CHOICES

Front Applications:

TD5510 Shackle Kit

International Models

TD4300 Shackle Kit

Sterling Models

TD4600 Shackle Kit

Freightliner Models

TD9610 Shackle Kit

Volvo Models: VN, VL

Rear Applications:

TD5044694 Rear Bushing Kit

Freightliner Models

TD4616412 Rear Bushing Kit

Freightliner, Sterling Models

**Other Applications are currently
available for:**

**Bluebird, Crane Carrier, Ford,
Freightliner, GMC, Kenworth, Mack,
Navistar, Peterbilt, Sterling, Thomas
Built, Volvo/White and Western Star.**

**Refer to Catalog for
Specific Applications**

**Proven Performance
Innovative Product
Superior Quality
Reliability**

Distributed By

URO® Systems, LLC

15678 King Drive

Meadville, PA 16335

(814)333-2985

www.urobushings.com

sales@urobushings.com

WARRANTY

**The bushing design is backed by a
three year parts warranty. All Front
Shackle Kits carry a 3 year parts and
labor warranty.**

Copyright 2007

Form TD2007-5TF

URO®

MAINTENANCE FREE SHACKLE

&

SUSPENSION SYSTEM

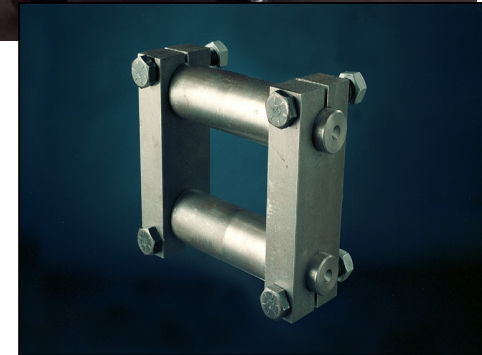

**THE ULTIMATE
RIDE SOLUTION**

A World of Benefits



URO® Suspension & Shackle Bushings are designed with specially formulated urethane, that is chemically resistant to grease, solvents, oils, and other road contaminants that suspension bushings come in contact with daily. They provide superior dampening and suspension control over the original equipment bushings. They extend component life & improve overall vehicle handling.

The bushings have proven performance in the field.

A full line of **URO**®

Suspension & Shackle Systems are available for most Class

6, 7 & 8 vehicles through

URO® Distributors

MAINTENANCE FREE

NO GREASE

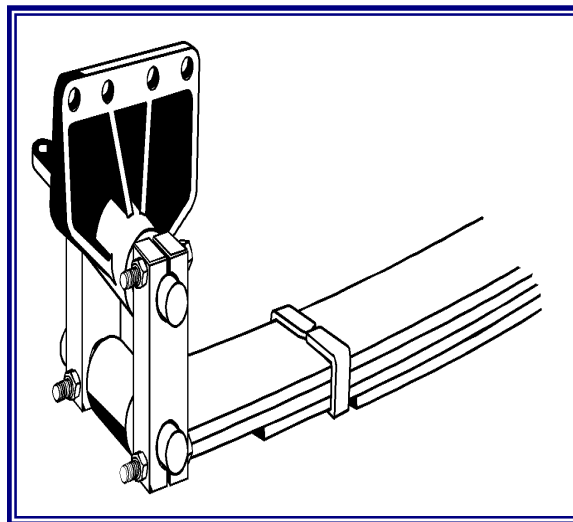

FREE ROTATION DESIGN

SELF LUBRICATING

EASY INSTALLATION

URO® Shackle & Suspension Systems

Provide Benefits:

- ▶ *Increased Control over suspension movement to maintain alignment, improves handling, and extend tire life.*
- ▶ *Better vibration and noise control to improve ride quality and handling, the result of quality materials, design, and manufacturing.*
- ▶ *Reduces overall maintenance costs.*
- ▶ *Increases service life 3 to 5 times.*
- ▶ *Easy installation, requiring no reaming, fitting or lubrication.*
- ▶ *Smoother, more comfortable ride.*