

Introducing

The only Shackle System that's designed and proven to meet the high performance standards of today's vehicles.

The **URO**® Suspension Systems provide the following Benefits:

- ◇ *Increased Control over suspension movement to maintain alignment, improve handling, and extend tire life.*
- ◇ *Better vibration and noise control to improve ride quality and handling, the result of quality materials, design, and manufacturing.*
- ◇ *Lowers overall maintenance costs. Increases service life 3 to 5 times.*
- ◇ *Easy installation, requiring no reaming, fitting or lubrication.*



15678 King Drive
Meadville, PA 16335

PSRST STD
U.S. POSTAGE PAID
MEADVILLE, PA
PERMIT NO. 3

UPGRADE TODAY!

1-800-541-3229

sales@urobushings.com

www.urobushings.com

URO®

Suspension Systems



PROVEN PERFORMANCE

The Ultimate Ride Solution

Application	Kit Type	<i>URO</i> [®] KIT	<i>URO</i> [®] Front of Front Kit	Comments
AMTRAN				
	Front	TD5520	TD551442	3" Spring
	Front	TD5550	TD551434	4" Spring
<i>Variable Rate</i>	Rear	TD105	—	Torque Leaf
	Rear	TD106	—	OVERSIZE
<i>Air Suspension</i>	Rear	TD5047691	—	
BLUEBIRD				
<i>All American, TC2000</i>	Front	TD1410	TD141489	Parabolic Spring
	Front	TD14125	—	Spring Eye Liner
<i>Variable Rate</i>	Rear	TD105	—	Torque Leaf
	Rear	TD5044694	—	Straddle Mount
FREIGHTLINER				
<i>FS65 Chassis</i>	Front	TD4640	—	4" Spring
	Front	TD4650	—	3" Spring
<i>Variable Rate</i>	Rear	TD4601050	—	
<i>FAS II</i>	Rear	TD4600234	—	Straddle
INTERNATIONAL				
<i>S Series</i>	Front	TD5570	TD551369	
<i>3600, 3700 Series</i>	Front	TD5560	TD75	Stamped Shackle
<i>3000, 4000, 8000 Series</i>	Front	TD5550	TD551434	4' Spring
<i>4400 Series</i>	Front	TD5510	TD550253	Rubber Bushing
<i>Genesis Chassis</i>	Front	TD5520	TD551442	3" Spring
<i>Variable Rate</i>	Rear	TD105	—	Torque Leaf
	Rear	TD106	—	OVERSIZE
<i>HAS Air Suspension</i>	Rear	TD5047691	—	
THOMAS BUILT				
<i>EF, ER Models</i>	Front	TD8820	TD961354	4" Spring
<i>MVP-EF 2nd Design</i>	Front	TD8810	TD880190	3-1/2" Spring
<i>Variable Rate</i>	Rear	TD5044694	—	
<i>FAS II Air</i>	Rear	TD8800234	—	

The *URO*[®] Shackle System has a freely rotating spring pin design and a specially formulated material that is self-lubricating and abrasion resistant. The *URO*[®] Shackle provides superior dampening and suspension control over the original equipment bushings. It extends component life and improves overall vehicle handling as well as greatly reduces

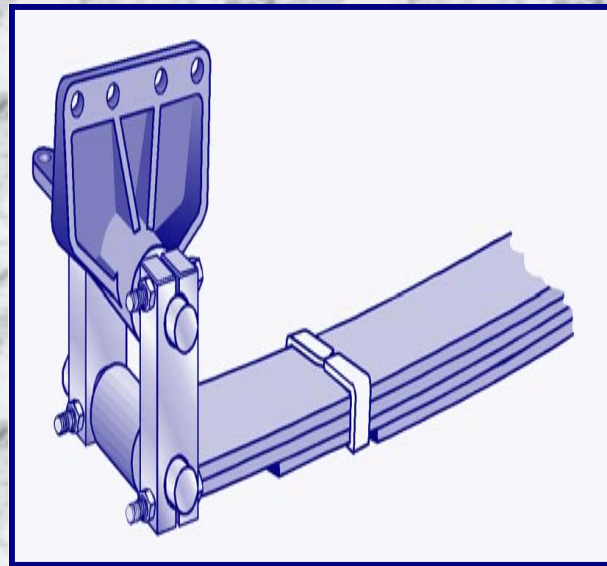

URO[®] Systems, LLC.

15678 King Drive

Meadville, PA 16335

(814)333-2985

800-541-3229

www.urobushings.com

sales@urobushings.com

URO[®] Systems, LLC.

©2007

All Rights Reserved. Printed in USA Form 2007-6TF

*ELIMINATES
SNAPPING*

&

POPPING

*MAINTENANCE
FREE*

PROVIDING A

SMOOTHER,

QUIETER RIDE

Refer to Application Catalog for Detailed Listings
and other Vehicle Applications